

# REKLUSE



## REKLUSE MOTOR SPORTS

---

The z-Start Pro Clutch

## INSTALLATION GUIDE

**Kawasaki KLR650**

191-640  
Manual Revision: 030308

©2007 Rekluse Motor Sports  
Rekluse Motor Sports, Inc.  
110 E. 43rd Street  
Boise, Idaho 83714  
208-426-0659  
[support@rekluse.com](mailto:support@rekluse.com)

# TABLE OF CONTENTS

<b>z-START PRO CROSS-SECTION VIEW</b>	<b>3</b>
<b>INCLUDED PARTS</b>	<b>3</b>
<b>REQUIRED TOOLS</b>	<b>3</b>
<b>BIKE PREPARATION AND DISASSEMBLY</b>	<b>4</b>
<b>INSTALLING THE z-START PRO CENTER CLUTCH</b>	<b>4</b>
<b>INSTALLING THE CLUTCH PACK</b>	<b>5</b>
<b>INSTALLING THE Z-START PRO CLUTCH</b>	<b>6</b>
<b>DETERMINE THE INSTALLED GAP OF THE Z-START PRO CLUTCH</b>	<b>8</b>
<b>SETTING CLUTCH CABLE SLACK</b>	<b>10</b>
<b>APPENDIX A – CENTER CLUTCH REMOVAL TIP SHEET</b>	<b>11</b>

## Z-START PRO CROSS-SECTION VIEW

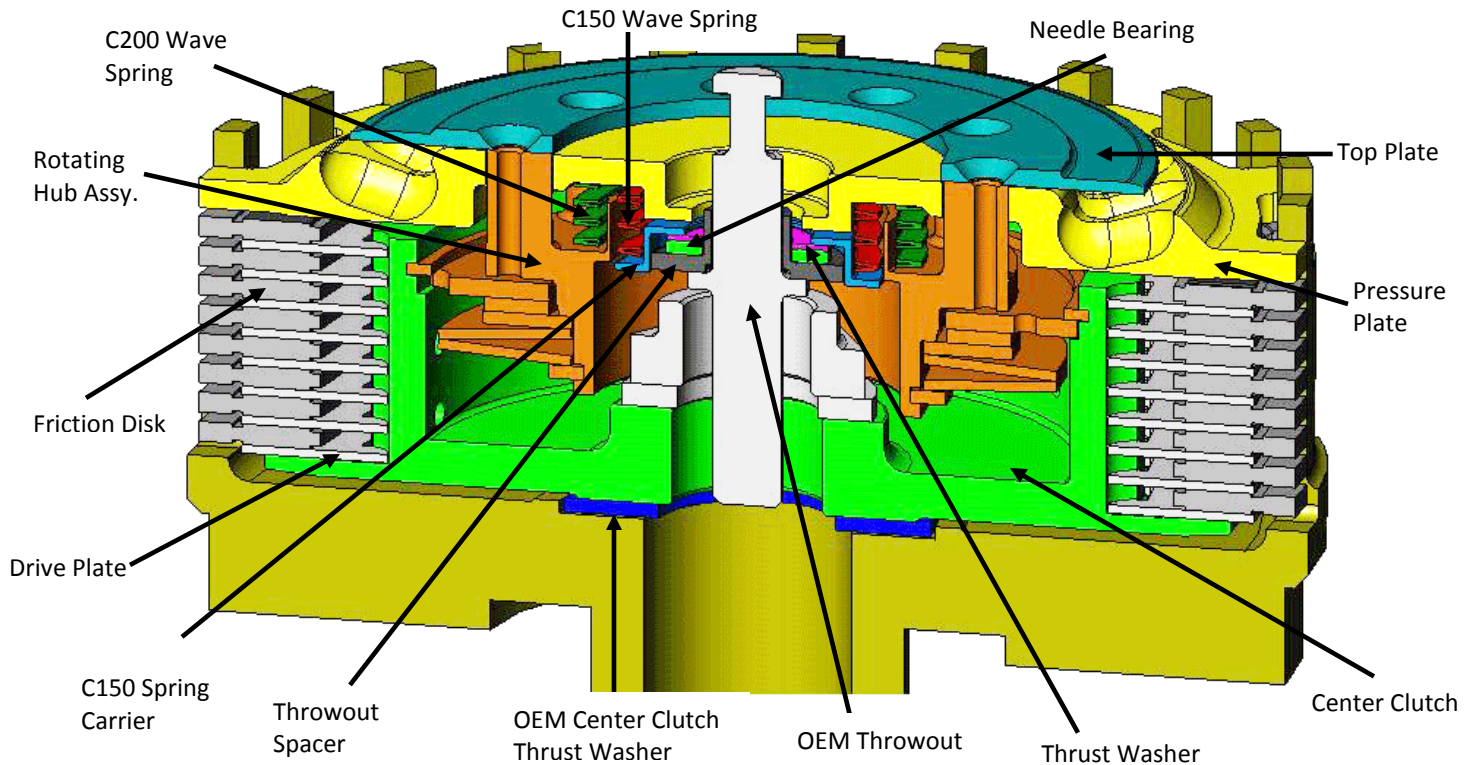

## INCLUDED PARTS

### Item

- Top Plate
- Pressure Plate
- Rekluse Center Clutch
- Retaining Ring
- (1) Pre-Measured Drive Plate Stack
- (1) RMS 0.065" Drive Plate (Adjustment Plate)
- (1) RMS 0.040" Drive Plate (Adjustment Plate)
- Rotating Hub Assembly

### Item

- Rekluse Throw-out Spacer
- Thrust Washer
- Thrust Bearing
- C150 Spring Carrier
- C150 Wave Spring
- C200 Wave Spring
- (27) 7/16" Tungsten Carbide Ball Bearings
- (10) M4x12 Torx Head Screws
- T-20 Torx Bit
- Blue Loctite 243
- Rekluse Wire Gauges

## REQUIRED TOOLS

- 8mm socket
- 10mm socket
- 27mm or 30mm socket (for center clutch nut)
- T-20 Torx bit (supplied)
- Impact Wrench

## BIKE PREPARATION AND DISASSEMBLY

1. Soak friction plates in oil for approximately 30 minutes.
2. Adjust your perch adjuster all the way in giving maximum slack to the clutch cable.
3. Drain coolant.
4. Shut off fuel at petcock. Lay bike over so that the left side of handlebar is supported approximately 2 ft. off ground (a typical motorcycle center stand works well for this). **CAUTION:** fuel may drain from carburetor; place a suitable container beneath bike to catch fuel to prevent fire hazard.
5. Remove rear brake lever.
6. Loosen clutch cable retainer nuts and detach clutch cable from actuator arm.
7. Remove water pump cover.
8. Remove water pump impeller.
9. Remove clutch access cover.

**NOTE:** Be careful not to damage gasket when removing clutch access cover, as it will be re-used.

10. Remove the bolts holding the 5 springs and the OEM pressure plate and remove the springs and pressure plate.
11. Remove stock throwout and bearing. Bearing **WILL NOT** be re-installed.

12. Remove the clutch pack (friction disks and drive plates). Separate the friction disks from the pack as they will be re-installed.
13. Remove the OEM center clutch via the center clutch nut.
14. Retain OEM thrust washer located between OEM clutch basket and OEM center clutch hub.

**NOTE:** thrust washer may be stuck to bottom of OEM center clutch hub.

## INSTALLING THE Z-START PRO CENTER CLUTCH

15. Install the Rekluse Center Clutch with the OEM thrust washer behind it on top of the basket.
16. Secure the Rekluse Center Clutch with the OEM nut and lock washer.
17. Torque the center clutch nut to the specified torque found in the manufacturer's service manual.

## INSTALLING THE CLUTCH PACK

18. The 8 Rekluse steel drive plates packaged with the Rekluse Center Clutch come pre-measured and are the 8 steel drive plates you will start with.

Install 1 Rekluse steel drive plate onto the Rekluse Center Clutch.

19. Install the stock friction disks with a Rekluse steel drive plate between each one. See chart below.

**NOTE:** Refer to step 1 before installing friction disks.

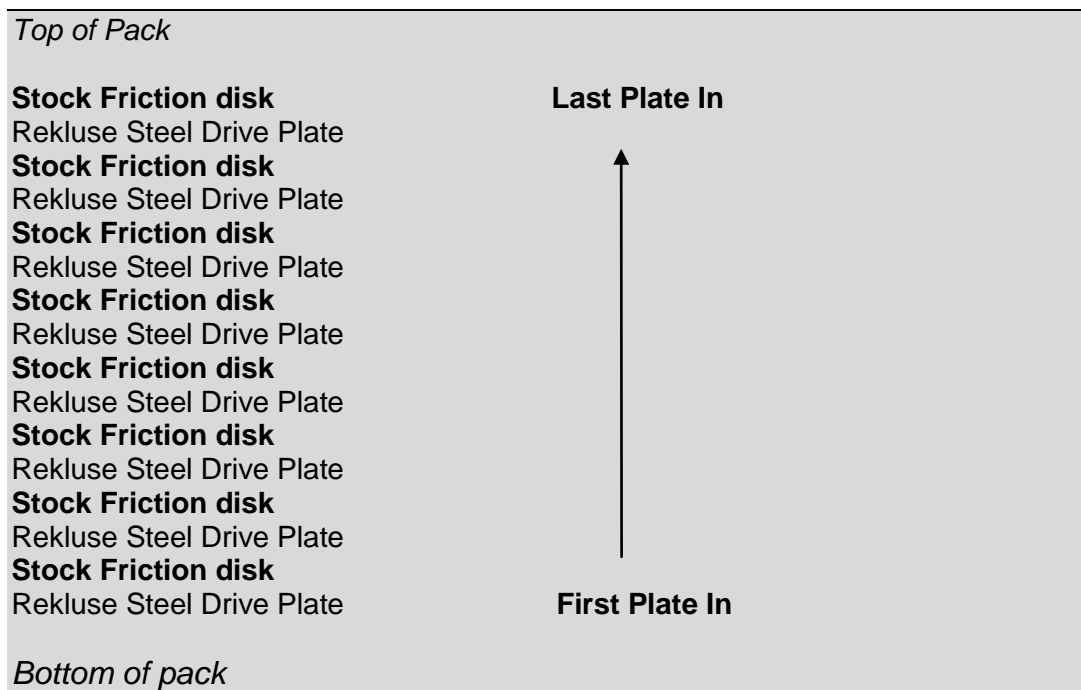

**Note:** The extra 0.065" thick drive plate and 0.040" thick drive plate are for adjustment and may be used later.

## INSTALLING THE Z-START PRO CLUTCH

20. Place lower assembly into Rekluse Center Clutch hub. You must align the cut-outs in the lower assembly with the corresponding tabs in the center clutch. Note: some models only have two cut-outs.

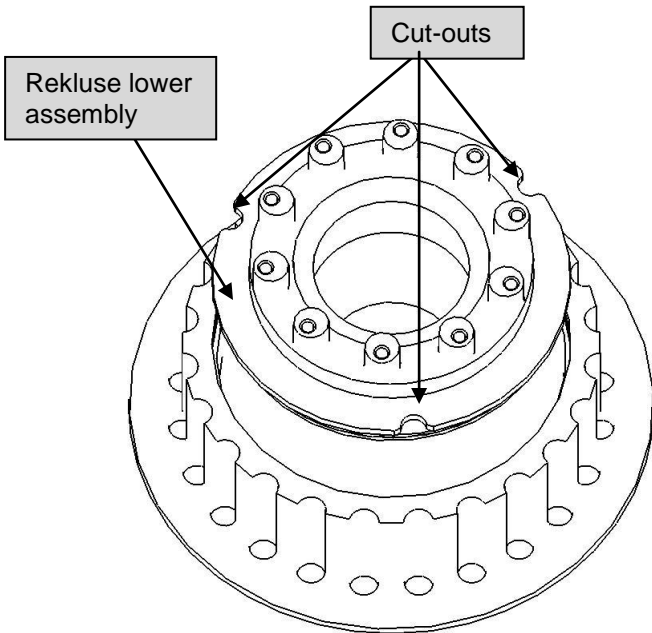

21. Using a pair of mechanics gloves (the edges of the ring can be sharp and may cut you), install the retaining ring into the Rekluse Center Clutch ring groove.

You must ensure the retaining ring is snapped into the groove. Start the square end of the ring and thread the ring into the groove as shown, ensuring that the scalloped end of the ring is clockwise in relation to the square end.

**WARNING: Scalloped end of ring MUST be oriented as shown above-right.**

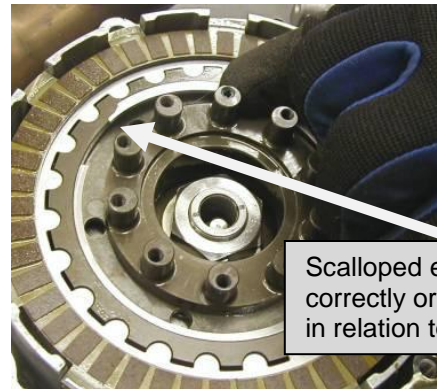

Scalloped end of ring correctly oriented: clockwise in relation to square end.

Threading retaining ring into groove

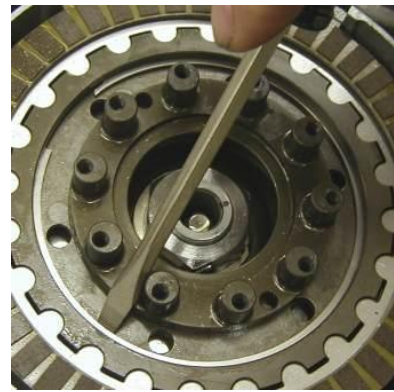

Use a screwdriver to ensure the ring is seated by sliding along the ring's inner diameter.

22. Install the OEM throw-out into the hole in the mainshaft.

23. Install the Rekluse throw-out spacer on top of the OEM throw-out followed by the needle bearing and thrust washer on top of it.

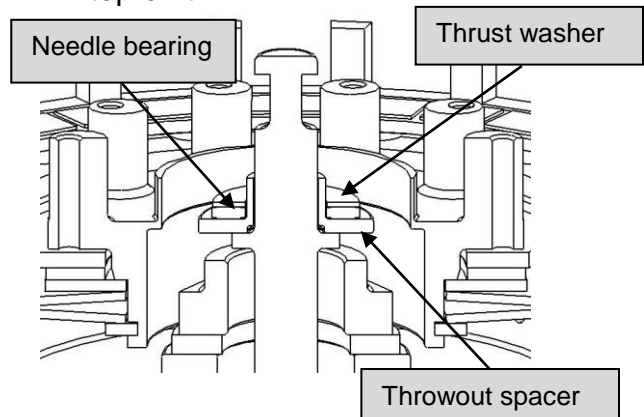

- 24.** Install the C150 Spring Carrier and the C150 wave spring on top of the throw-out thrust washer.

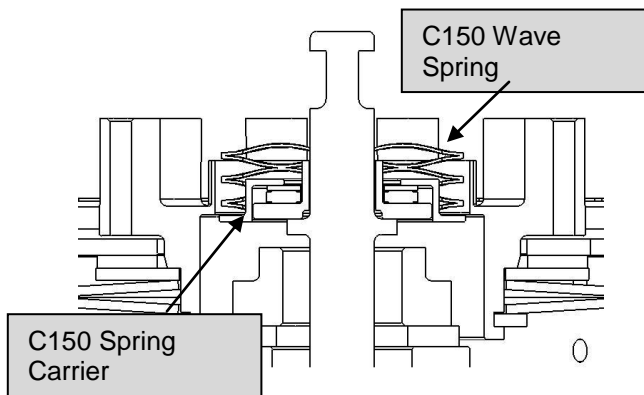

- 25.** Install the C200 wave spring on top of rotating hub into the locating pocket.

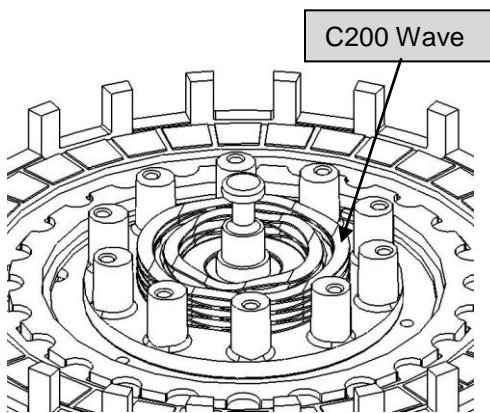

- 24.** Place a small amount of oil into the ball grooves of the Rekluse Pressure Plate.
- 25.** Away from the bike, install the balls into the pressure plate ball grooves.
- 26.** Place the Rekluse pressure plate, with balls, over the lower assembly. Line the 10 holes in the pressure plate up with the 10 rotating hub posts. Also, line the outer tabs of the pressure plate up with the basket slots. Index the top of the throw-out inside the center hole of the Rekluse Pressure Plate.

- 27.** Push and hold the pressure plate down, overcoming the wave springs pressure, so the 10 rotating hub posts index into the 10 pressure plate holes.

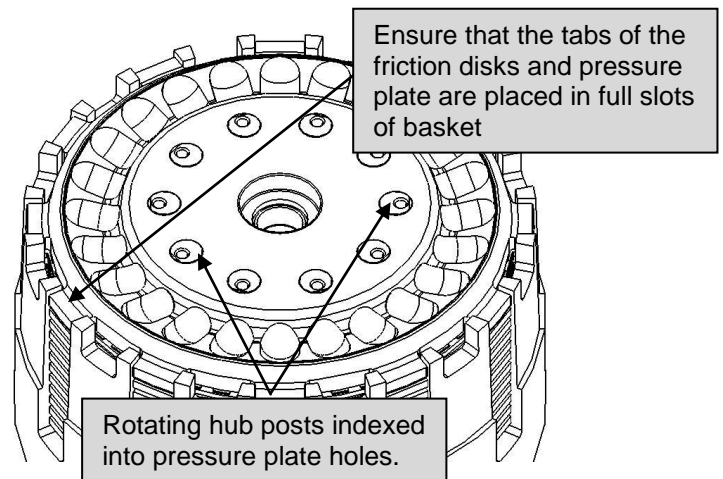

- 28.** While holding down the pressure plate so it is indexed with the basket and 10 rotating hub posts properly, place the Rekluse top plate over the Rekluse pressure plate and thread in 2 torx head screws 180° across from one another. Lightly tighten the 2 screws to secure the Rekluse top plate.



## DETERMINE THE INSTALLED GAP OF THE Z-START PRO CLUTCH

**Note:** Installed gap is measured using two wire gauges. Two sets of gauges are included: .030" and .050". Desired gap range is .030"-.050".

29. Verify that top-most friction disk moves up and down freely between the Pressure Plate and top-most steel drive plate by pulling up and down on top-most friction disk. If no "float" exists, top-most **steel drive plate** has become disoriented during previous step and needs to be re-installed.
30. Attempt to slide the shorter legs of the 2 included 0.030" wire gauges **between the Rekluse pressure plate and the friction pads** of the top friction disk 180° apart.

Gauges should slide in with slight resistance. Do not force the gauges in, if the gauges **do not** slide in smoothly then the Installed Gap is too small and needs adjustment according to step 31. If the gauges slide in with slight resistance, advance to step 32.

Use the small leg of wire gauges.

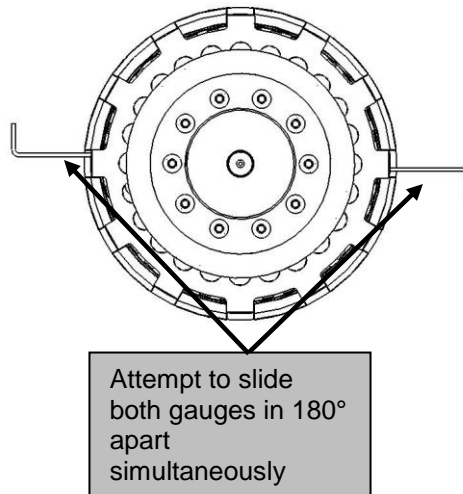
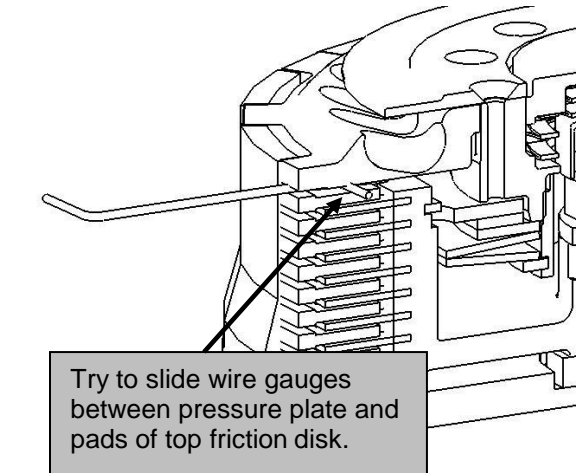
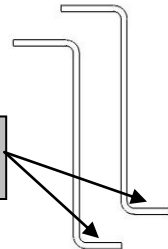

**NOTE:** The gauges need to slide in past the "relief" point on the underside of the pressure plate to get an accurate measurement.

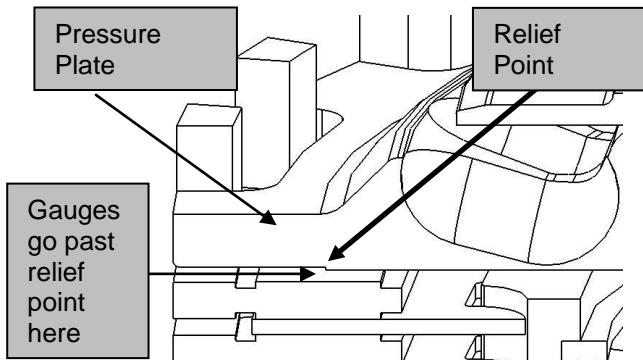

31. If the .030" wire gauges do not slide in smoothly, the clutch pack needs adjustment. Swap the .040" Rekluse adjustment drive plate for the second drive plate from top of stack. Repeat step 30.

32. Attempt to slide the shorter legs of the 2 included .050" wire gauges **between the Rekluse pressure plate and the friction pads** of the top friction disk 180° apart.

The .050" gauges should **NOT** slide in. If the gauges **do** slide in smoothly then the Installed Gap is too large and needs adjustment according to step 33. If the gauges **DO NOT** slide in, the Installed Gap is good. Advance to step 34.

33. If the .050" wire gauges slide in smoothly, the clutch pack needs adjustment. Swap the .065" Rekluse adjustment drive plate for the top drive plate. Repeat step 32.

**NOTE:** In sum, .030" wire gauges **SHOULD** slide in and .050" wire gauges **SHOULD NOT** slide in.

34. Install the remaining 8 torx head screws using blue Loctite 243 and torque to 14 in-lbs.

35. Remove the 2 screws originally installed without Loctite, apply Loctite and torque.

36. Remove actuator arm. Be careful not to damage seal.

37. ***Orient arm as shown below and above right, noting position of slot.*** Grind or file .030"-.040" (~ 1mm) of material from the actuator arm. Start the removal 1.4" from bottom of actuator arm as **shown below**.

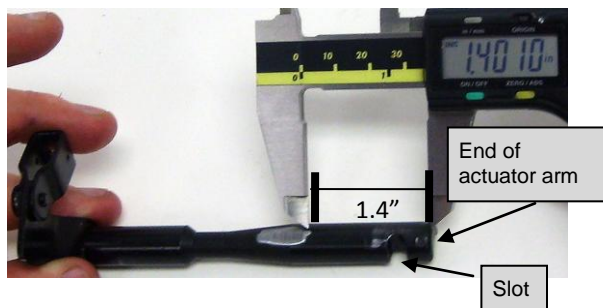

Grind should be .622" in width. **See photo below.**

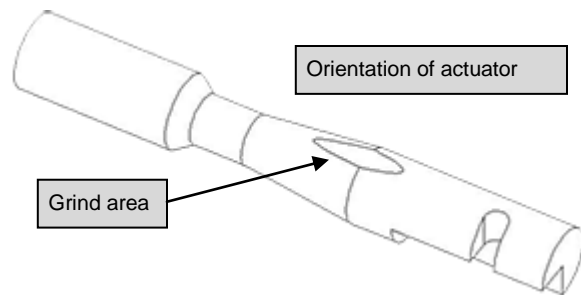

38. Re-install the clutch cover with OEM gasket. As you slide the cover on be careful not to damage the water pump shaft seal.

39. Also, you will have to rotate the actuator arm to engage the throw-out in order to fully seat the cover. Lightly tighten all of the cover bolts before full torque is applied, or you may break the cover.

40. Place impeller onto water pump shaft and secure with nut. Torque to manufacturer's recommended value.

**WARNING:** Do not over-torque nut or water pump shaft will be damaged.

41. Re-install water pump cover.

42. Re-attach clutch cable to actuator arm.

43. Re-attach threaded cable end to cover support bracket with the clutch cable retainer nuts.

44. Fill radiator with coolant.

**WARNING:** Cable slack adjustment is **CRITICAL**. Adjust cable slack according to instructions on following page.

## SETTING CLUTCH CABLE SLACK

**IMPORTANT:** Cable slack adjustment is **critical**. The cable slack must be adjusted properly and maintained frequently. Failure to do so will result in clutch failure.

Adjusting cable slack is different with a z-Start Pro Clutch installed. Cable slack adjustment requires starting the motor in neutral and revving to a minimum of 4500 RPMs (approximately ½-throttle) while checking for lever free play. **There must be clutch lever free play while holding a minimum of 4500 RPMs.**

**If there is not enough cable slack, the clutch will slip excessively causing the clutch to fail.** Too much cable slack reduces the ability to disengage the clutch at higher RPMs.

**WARNING:** *Ensure the bike is in neutral* or it could lunge forward unexpectedly when revving the engine.

**Place the bike into neutral and start the engine.** While holding a minimum of 4500 RPMs, check for 1/2" (1cm) of play at the end of the clutch lever before you feel significant resistance. Adjust cable slack accordingly using stock cable slack adjuster(s).

In other words, when revving the engine, clutch lever free play should feel like stock.

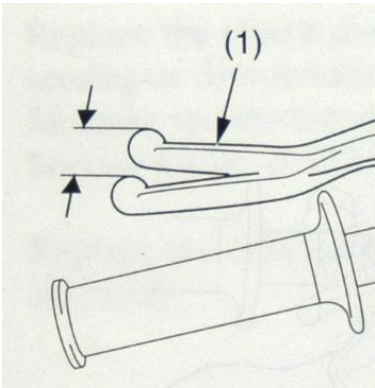

**Tip:** Use one finger with light pull when checking for lever free play. This will make it easier to distinguish between the light resistance of the lever return spring and the significant resistance felt when disengaging the Rekluse pressure plate.

**Note:** Be sure to review the included Break-in and Maintenance Guide for clutch pack wear adjustments.

**WARNING:** After a 20 minute break-in period, the clutch plates will seat in and you must re-measure the Installed Gap to guarantee the Installed Gap is within the prescribed range—make drive plate adjustments if necessary. Clutch break-in re-measurement of the Installed Gap is necessary whenever new clutch plates are installed.

Refer to the “Safety Warnings” and “Break-in Tuning and Maintenance Guide” before operating the z-Start Pro clutch.

## APPENDIX A – CENTER CLUTCH REMOVAL TIP SHEET

The following covers 3 methods for removing the OEM center clutch from your motorcycle or ATV. **At no time should you ever pry against the standoffs of the OEM center clutch because they are easily broken.**

**Note:** If your bike has an external tab lock washer, use a flat blade screwdriver to pry the tabs away from the nut. Next use a hammer and punch to lightly tap the tabs flat.

- 1. Pneumatic or electric impact gun:**  
Place the bike in gear and remove the nut
- 2. Clutch Holding Tool:**  
Example: Motion Pro # 08-0008  
Use the clutch holding tool to hold the center clutch while using a wrench to remove the center clutch nut.
- 3. Holding the Rear Brake:**  
Place the bike in 4<sup>th</sup> or 5<sup>th</sup> gear (a higher gear gives you more mechanical advantage).  
Apply the rear brake firmly and hold firmly while using a wrench to remove the center clutch nut. A second set of hands is helpful.